

# Sanitary Filter Housing Multi-Round Series



The High Purity Sanitary Cartridge housings are designed to meet your critical processing needs. These housings are commonly used in the Pharmaceutical, Biotechnology and Food and Beverage industries. These housings are ideal for Sterile filtration applications. These housings have machined cartridge connections, not seat cups that cause hold up volume, no threaded connections and using only superior grade 316L stainless steel.

The housings are available in 222 or 226 o-ring style. DOE available with customization. A complete line of housings from 3 to 12 round and in lengths from 10 to 40 inches are available to meet the needs of your critical applications. The design of the housing provides a positive seal and can be completely dismantled, (including a removable seat plate) allowing for access to all internal surfaces for cleaning.

Sanitary vent & drain valves allow easy venting, draining and sampling. Secure swing bolt closure design. Custom options are available and include: handles, Tri-Clover vent and drains, upstream and downstream drains and choice of Tri-Clover inlet/outlet connection sizes.



### Materials of Construction

- Head: 316L Stainless Steel
- Bowl: 316L Stainless Steel
- Center Post with Seal plate: 316L SS
- Vent/ Drain Plug: 316L Stainless Steel
- O-Rings: Silicone, Viton or EPDM

### Dimensions (nominal)

Lengths (in): 10, 20, 30 and 40

### Connections

- Inlet/ Outlet : Tri Clamp, Flange, Butt Weld
- Vent / Drain : Tri Clamp, Hose Barb

### Finish

- Interior: Ra <20 uin (<0.4um)
- Exterior: Ra <32 uin (<0.8um)

### Operating Conditions

Max operating pressure: 100 psi (6.8 Bar)

Applications	
Pharmaceuticals	Biologics
WFI	Food & Beverage
Reagents	Wine
Fine Chemicals	Electronics

Features	Benefits
<ul style="list-style-type: none"> <li>• Aseptic Design</li> </ul>	<ul style="list-style-type: none"> <li>• Crevice Free Electropolished surfaces with Ra &lt;20 µin (&lt;0.4um)</li> <li>• Fully Self draining</li> <li>• No Dead Legs</li> <li>• Can be completely dismantled</li> </ul>
<ul style="list-style-type: none"> <li>• Low Hold Volume</li> </ul>	<ul style="list-style-type: none"> <li>• Maximize Product Recovery</li> </ul>
<ul style="list-style-type: none"> <li>• Easy to use low point drain valve</li> </ul>	<ul style="list-style-type: none"> <li>• Removable for cleanability</li> <li>• Ease of filter change-out</li> </ul>

## Sanitary Filter Housing Multi-Round Series

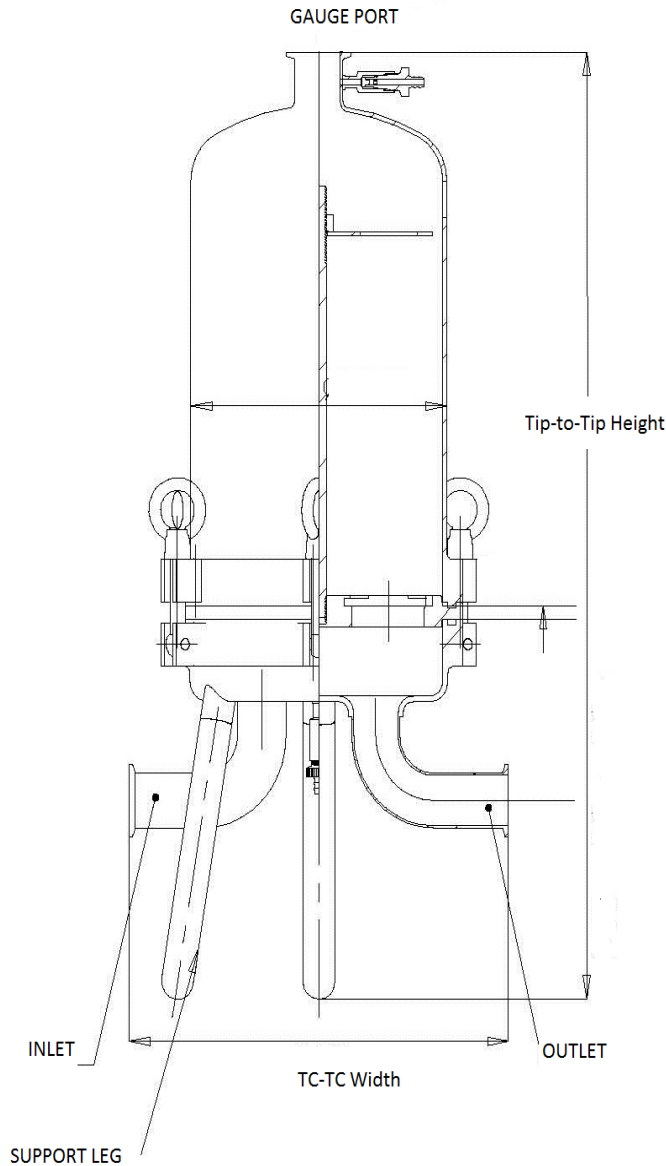

Nominal Dimensions

Number of Cartridges	Cartridge Height (in)	Tip to Tip Height (mm)	TC-TC Width (mm)	Inlet/Outlet (in)
3 round	10	670	300	1.5 TC
	20	920	300	1.5 TC
	30	1170	300	1.5 TC
	40	1420	300	1.5 TC
5 round		Tip to Tip Length	TC-TC Width	Inlet/Outlet
	10	675	340	1.5 TC
	20	925	340	1.5 TC
	30	1175	340	1.5 TC
7 round		Tip to Tip Length	TC-TC Width	Inlet/Outlet
	10	713	380	2 TC
	20	963	380	2 TC
	30	1213	380	2 TC
9 round		Tip to Tip Length	TC-TC Width	Inlet/Outlet
	20	1017	380	2 TC
	30	1267	380	2 TC
	40	1517	380	2 TC
12 round		Tip to Tip	TC-TC	Inlet/
	20	1017	500	3 TC
	30	1267	500	3 TC
	40	1517	500	3 TC

Your Local Distributor:

**PharmBiologic Solutions, LLC**

**317-415-0179**