

Horizontal Large Diameter Multi-Cartridge Filter Vessel



The Horizontal Large Diameter Multi-Cartridge Filter Vessels are designed to meet your critical processing, high flow needs. These housings are commonly used in the Industrial, Food and Beverage and Water Treatment applications. These housings are ideal using only superior grade 316L or 304L stainless steel.

The housings are available for 6" large diameter cartridges. A complete line of housings from 1 to 12 round and in lengths of 20, 40, and 60 inches. The design of the housing provides a positive seal with swing bolt closure and cover davit arm.

Custom options are available and include: upstream and downstream drains and choice of inlet/outlet connection sizes.



Materials of Construction

- Head: 316L/304L Stainless Steel
- Bowl: 316L/304L Stainless Steel
- Filter Basket: 316L/304L SS
- Vent/ Drain Plug: 316L/304 Stainless Steel
- O-Rings: Viton, EPDM, Buna, Silicone

Applications
Process Water
Food & Beverage
Fine Chemicals

Dimensions (nominal)

Lengths (in): 20, 40, 60

Connections

Inlet/ Outlet : Butt Weld, Tri-Clamp, Flange and BSP
Vent / Drain : NPT

Finish

Exterior & Interior Finish: Mirror or Matte Polish

Operating Conditions

Max operating pressure: 150 psi @ 250F

Features	Benefits
<ul style="list-style-type: none"> ■ Industrial Design 	<ul style="list-style-type: none"> ■ Offset ■ Fully Self draining ■ No Dead Legs
<ul style="list-style-type: none"> ■ Low Hold Volume 	<ul style="list-style-type: none"> ■ Maximize Product Recovery
<ul style="list-style-type: none"> ■ Easy to use low point drain valve 	<ul style="list-style-type: none"> ■ Ease of filter change-out

Horizontal Large Diameter Multi-Cartridge Filter Vessel



INDUSTRIAL LARGE DIAMETER HORIZONTAL VESSEL

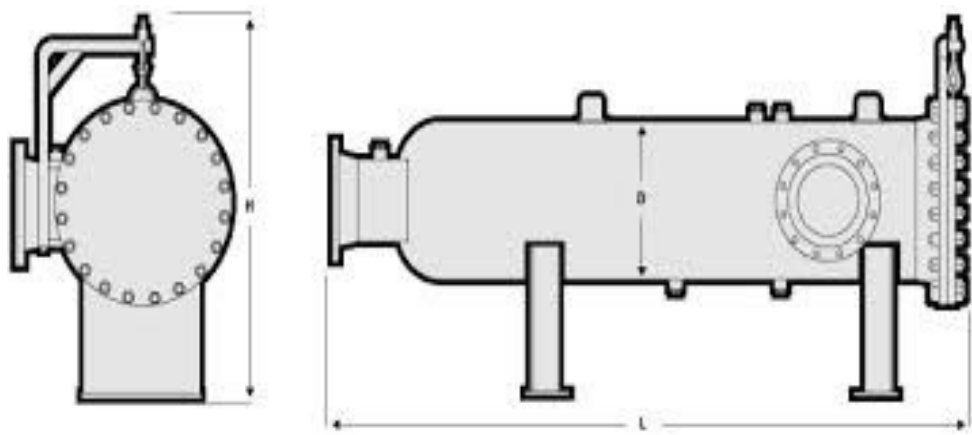

Your Local Distributor:

Please Visit Us At:

www.pharmbiologicsolutions.com

Email: info@pharmbiologicsolutions.com

317-415-0179 phone 317-536-3937-fax