

QUALIKAP QKP-T

PTFE membrane capsule filters

- Inherently Hydrophobic Membrane
- Sterilizable in autoclave
- Enhanced gas permeability
- Thermowelded assembly
- EC-listed materials for food contact
- FDA-listed materials per CFR21
- Extractables as per USP for plastic materials
- Validation Guide available



QUALIKAP QKP-T capsules are especially designed to be used as sterilizable final filter for small batches where a fluid free from particle and/or biological contaminants is required. QUALIKAP QKP-T are fitted with a pleated hydrophobic PTFE membrane filter element, that guarantees enhanced performance in gas, alcoholic solution and solvent filtration, typical in pharma, cosmetic and food & beverage applications. The capsules are available with a filtration grade of 0,1 and 0,2 micron.

The filter elements are manufactured in a controlled environment; each filter element is tested to verify the integrity.

Each capsule is supplied with a conformity test certificate showing the lot.

MATERIALS OF CONSTRUCTION

Membrane	PTFE membrane
Upstream drainage layers	polypropylene
Downstream drainage layers	polypropylene
Core and Cage	polypropylene
Outer Shell	polypropylene
Terminals	polypropylene

FOOD-SAFETY

QUALIKAP-QKP-T capsules meet regulation (EC) 1935/2004 for indirect food contact.

BIO-SAFETY AND EXTRACTABLES

- Materials are compliant to USP-VI CLASS toxicological requirements and USP-Plastic Materials chemical and physical requirements.
- Capsule filters meet USP "Water for injection" requirements for endotoxin and particle release; the bacterial endotoxin is determined using LAL Test.

RECOMMENDED OPERATING CONDITIONS

- max. continuous temperature	40 °C
- max. cumulative time of steam sterilization (no in line sterilization available)	50 hours at 135 °C (30' cycle)
- max. pressure with liquids	5 bar at 40 °C - 5,5 bar at 25 °C
- max. pressure with gas	3,0 bar at 30 °C
- max. differential pressure	5,0 bar at 40 °C with liquids - 3,0 bar at 30 °C with gas
- recommended pressure drop for changeover	2,0 bar at 25 °C

CODE	ABSOLUTE FILTRATION GRADE IN LIQUIDS	3) BACTERIAL RETENTION >10 ⁷ CFU/cm ²	ACCEPTABLE LIMIT FOR INTEGRITY TEST
SH	0,1 µm	Acheleoplasma laidlawii in liquid	1) ≤ 6 ml/min @ 1,3 bar
SL	0,2 µm	Brevundimonas diminuta	1) ≤ 6 ml/min @ 0,8 bar
SLA	0,2 µm	Brevundimonas diminuta	2) ≤ 7 Nml/10min @ 2,5 bar

Note:

1- The integrity is verified by DIFFUSION TEST using an aqueous solution of isopropyl alcohol (IPA 60/40 V/V) as wetting liquid.

2- The integrity is verified by WATER FLOW INTRUSION TEST.

3- Cartridges are validated for retention of the microorganism reported in the table according to ASTM F838-05.

AIR FLOW RATE CHARTS

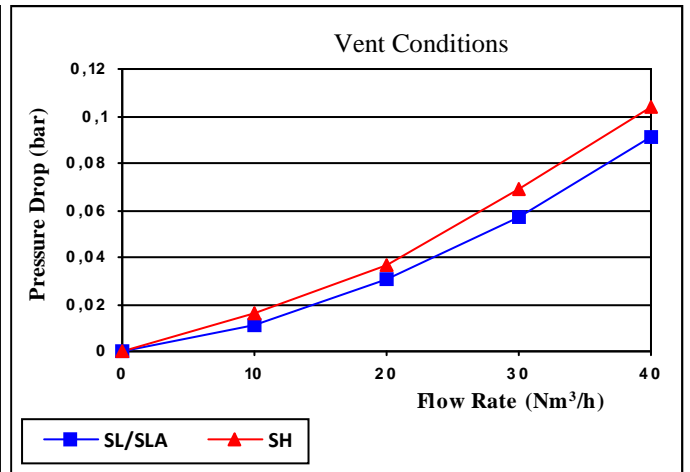
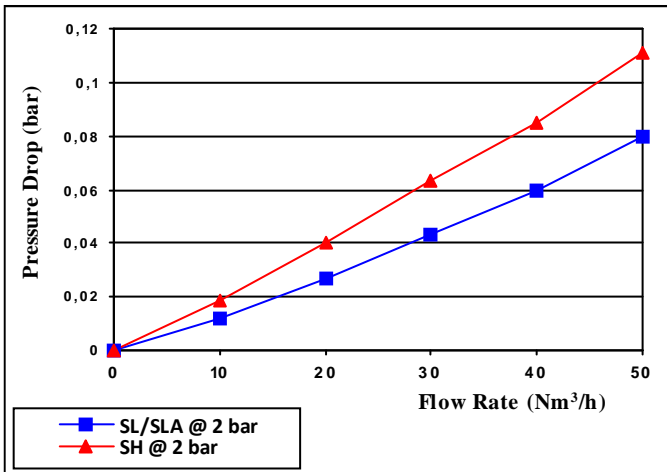

QUALIKAP QKP-T ORDERING INFORMATION

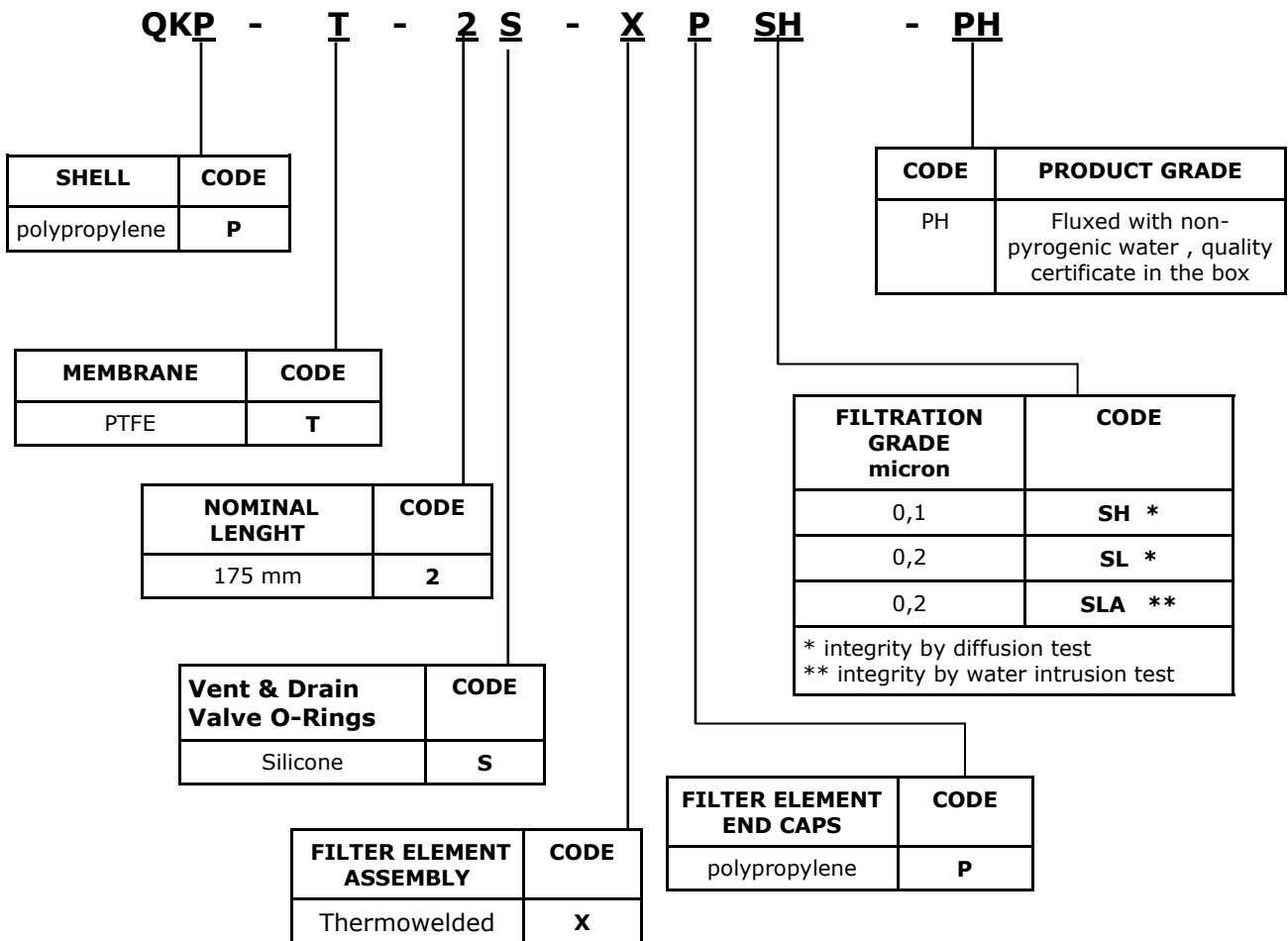

- Max diameter (valves included): 117 mm
- Tri-clamp connections 1 1/2"

Data contained in this bulletin are informative and subject to change without notice.
 User is responsible for determining whether the product is fit for particular purpose and suitable for User's method of application.



Bea Technologies Spa Via Newton, 4 - 20016 Pero (Milano) ITALY
 Tel +39 02 339271 FAX +39 02 3390713 e-mail: info@bea-italy.com
 web: www.bea-italy.com